

ELECTROMAGNETIC VIBRATORS (LINEAR) FOR HOPPERS

One degree of freedom

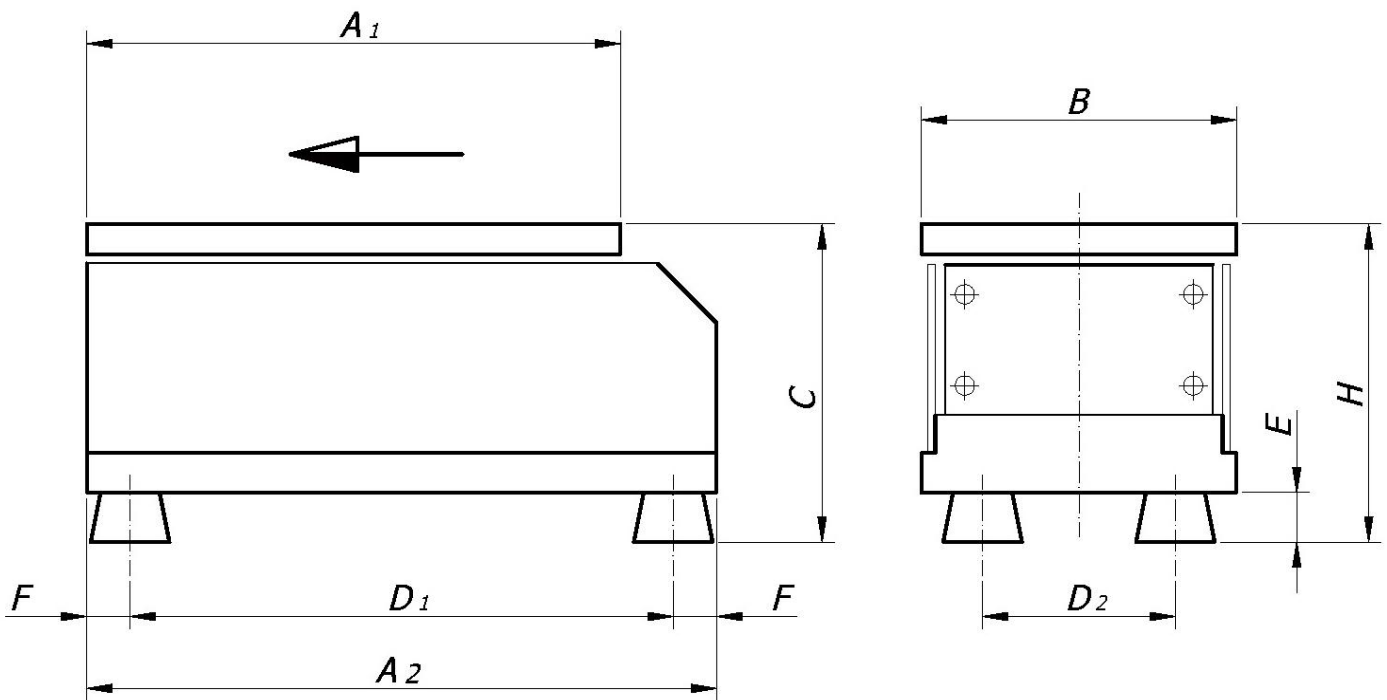

Vibrator model	Measurements (mm)								Weight (~) kg	Elastic supports (See A-02.00)	Maximum consumption (Amp)
	A1	A2 max.	B	C	D1	D2	E	F			
VD-20	320	350	110	148	286	66	25	17	20	00352-	0,6
VD-30	285	320	160	170	276	98	25	25	22	00352-	0,6
VD-60	380	420	260	230	344	164	35	38	64,5	00353-	2,6
VD-70	620	660	260	230	584	164	35	38	101	00352-	5,2

NOTES

- 1.- The "C" measurement may vary slightly to the same extent as the "E" measurement (manufacturing tolerance of the elastic supports and compression, according to hardness and weight supported – see technical sheet A-02.00).
- 2.- The electrical consumption detailed here is the maximum on a standard connection: 230 V (single-phase) / 50 or 60 Hz.