

ELECTROMAGNETIC VIBRATORS (LINEAR) FOR GUIDES

One degree of freedom

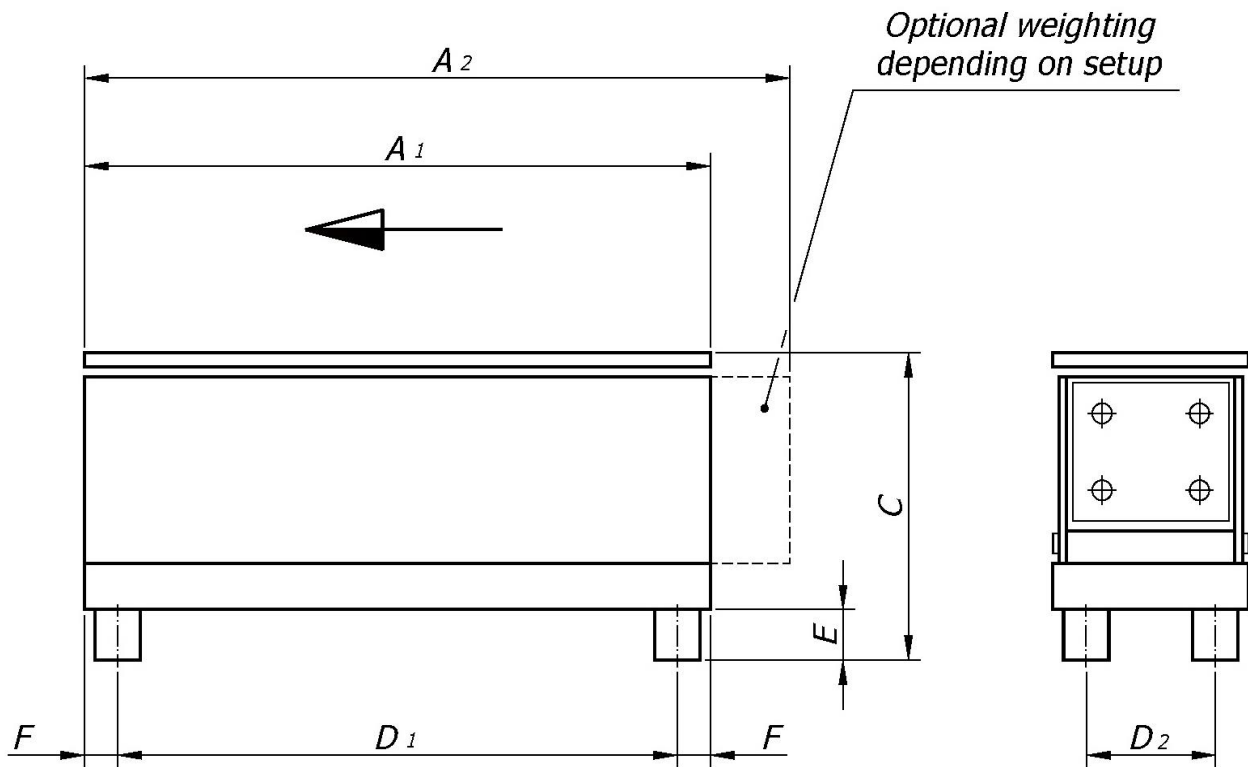

Vibrator model	Measurements (mm)								Weight (~) kg	Elastic supports (See A-02.00)	Maximum consumption (Amp)
	A_1	A_2 max.	B	C	D_1	D_2	E	F			
VL-30	224	284	80	120	184	42	22	20	11	00351-	0,2
VL-60	320	380	110	148	286	66	25	17	23	00352-	0,6
VL-70	562	622	110	153	528	66	25	17	34	00352-	1,2
VL-80	740	800	110	153	706	66	25	17	45	00352-	1,8

NOTES

- 1.- The "C" measurement may vary slightly to the same extent as the "E" measurement (manufacturing tolerance of the elastic supports and compression, according to hardness and weight supported. See technical sheet A-02.00).
- 2.- The electrical consumption detailed here is the maximum on a standard connection: 230 V (single-phase) / 50 or 60 Hz.